



TALGIL COMPUTING & CONTROL LTD.
NAAMAN CENTER, HAIFA - ACCO ROAD
ISRAEL
P.O. BOX 775 KIRYAT MOTZKIN 26119
TEL: 972-4-9506051 , 9506052
FAX: 972-4-8775949

DREAM RF RTU SYSTEM

GUIDE

Generations III, IV, IV.V



contents

1. SYSTEM OVERVIEW.....	- 4 -
2. SETTING UP AN RF RTU SYSTEM.....	- 7 -
2.1 <i>SETTINGS TO BE DONE AT THE HOST CONTROLLER</i>	<i>- 8 -</i>
2.2 <i>SETTING UP THE INTERFACE AND THE RF MASTER</i>	<i>- 9 -</i>
2.3 <i>SETTING UP THE RF SLAVE.....</i>	<i>- 11 -</i>
2.4 <i>SETTING UP THE RF RTU BASE.....</i>	<i>- 12 -</i>
2.4.1 <i>Setting the RTU address</i>	<i>- 13 -</i>
2.4.2 <i>Defining the polling rate.....</i>	<i>- 13 -</i>
2.4.3 <i>Setting the layer.....</i>	<i>- 13 -</i>
2.4.4 <i>Setting up a repeater.....</i>	<i>- 14 -</i>
2.4.5 <i>Functions of the jumpers</i>	<i>- 15 -</i>
3. THE VARIOUS MODES OF OPERATION.....	- 15 -
3.1 <i>START-UP MODE</i>	<i>- 15 -</i>
3.2 <i>NORMAL MODE</i>	<i>- 15 -</i>
3.3 <i>RF TEST MODE.....</i>	<i>- 15 -</i>
3.4 <i>WHEN LOOSING COMMUNICATION.....</i>	<i>- 16 -</i>
3.5 <i>TESTING INPUTS AND OUTPUTS</i>	<i>- 16 -</i>
3.6 <i>LOW BATTERY INDICATION.....</i>	<i>- 17 -</i>
4. READING ANALOG INPUTS BY RF RTUS	- 18 -
4.1 <i>SETTING THE INTERFACE FOR ANALOG INPUTS</i>	<i>- 18 -</i>
4.2 <i>SETTING THE RTU FOR ANALOG INPUTS.....</i>	<i>- 18 -</i>
4.3 <i>SETTING THE DREAM FOR READING RF ANALOG INPUTS.....</i>	<i>- 19 -</i>
5. USING RFPROG FOR PROGRAMMING THE RTU	- 20 -
5.1 <i>ANALOG INPUTS PARAMETERS</i>	<i>- 21 -</i>
5.2 <i>THE SOLENOIDS ACTIVATION PULSE PARAMETERS</i>	<i>- 22 -</i>
5.3 <i>INPUTS PULSE DIVISION.....</i>	<i>- 22 -</i>
5.4 <i>THE AUTO CLOSE PARAMETERS</i>	<i>- 22 -</i>
6. SOUNDS and LED LIGHTS	- 23 -
6.1 <i>RTU+SLAVE during START UP</i>	<i>- 23 -</i>
6.2 <i>RTU BASE+SLAVE during normal communication</i>	<i>- 23 -</i>
6.3 <i>BASE+SLAVE while losing communication.....</i>	<i>- 23 -</i>
6.4 <i>BASE+SLAVE during RF test - COMMUNICATION OK.....</i>	<i>- 23 -</i>
6.5 <i>BASE+SLAVE during RF test – NOT RECEIVING</i>	<i>- 24 -</i>
6.6 <i>No communication between BASE and SLAVE.....</i>	<i>- 24 -</i>
6.7 <i>BASE during inputs test.....</i>	<i>- 24 -</i>
6.8 <i>BASE during outputs test.....</i>	<i>- 24 -</i>
6.9 <i>BASE when battery becomes low.....</i>	<i>- 25 -</i>



6.10	<i>INTERFACE+MASTER during normal operation - RF OK</i>	- 25 -
6.11	<i>INTERFACE not communicating with the MASTER</i>	- 25 -
6.12	<i>INTERFACE not communicating with the DREAM</i>	- 25 -
6.13	<i>BASE ENTERING PROGRAMMING MODE</i>	- 25 -
6.14	<i>SLAVE ADDRESS ZERO</i>	- 25 -
APPENDIX A - Decimal to binary conversion table		- 26 -
APPENDIX B - WIRING		27
	<i>Wiring between DREAM – RF INTERFACE (internal) and RF MASTER</i>	27
	<i>Wiring between DREAM – RF INTERFACE (internal) and RF MASTER</i>	27
	<i>Wiring between RTU BASE and RF SLAVE</i>	28
	<i>Wiring of Outputs and Inputs into the RTU BASE:</i>	29
APPENDIX C – THE RF EAR		30
	<i>HOW TO USE THE RF EAR ?</i>	30

This equipment has been tested and found to comply with the limits for a Class A digital device, pursuant to Part 15 of the FCC Rules. These limits are designed to provide reasonable protection against harmful interference when the equipment is operated in a commercial environment.

This equipment generates, uses, and can radiate radio frequency energy and, if not installed and used in accordance with the instruction manual, may cause harmful interference to radio communications. Operation of this equipment in a residential area is likely to cause harmful interference in which case the user will be required to correct the interference at his own expense.

Changes or modifications not expressly approved by the manufacturer could void the user's authority to operate the equipment

THE RF RTU SYSTEM GENERATION III, IV, IV.V

1. SYSTEM OVERVIEW

The RF RTU system is designed to work in conjunction with the DREAM irrigation control system, with the UNILINER, MINILINER and OASIS systems, enabling them to reach remote Input and Output (I/O) devices by wireless means.

Generations GIV and GIV.V were developed after GIII in order to improve the frequency separation ability and to cover different frequency ranges. GIII, GIV and GIV.V are not compatible. The picture below shows the RF units of the three kinds. Remember - in the same system all RF units must be of the same type:

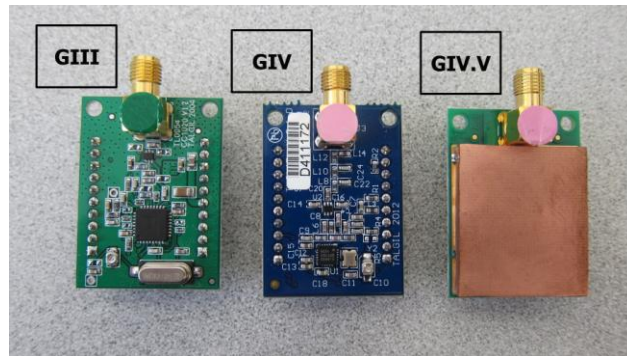

The RF module 4.5 complies with part 15 of the FCC rules. Operation is suitable to the following conditions:

- (1) this device may not cause harmful interference .
- (2) this device must accept any interference received , including interference that may cause undesired operation.

The RF system consists of the following parts:

1. The **RF MASTER** – The central receiver/transmitter unit. Includes an RF unit with antenna, should be installed on top of a high pole located next to the host controller.

All the communication with all the RTU units on site, goes through the RF MASTER, therefore it should be carefully positioned at a place from where it may have a clear line of sight to most of the RTU units.



2. The **RF INTERFACE** – serves as a link between the RF MASTER and the host controller. When possible, the RF INTEFACE will be placed inside the enclosure of the host, otherwise it will have its own enclosure and then the interface will be connected to the host by a shielded 4 wired cable that can be a few hundred meters long. Similarly the communication to the RF MASTER uses also a shielded 4 wired cable.

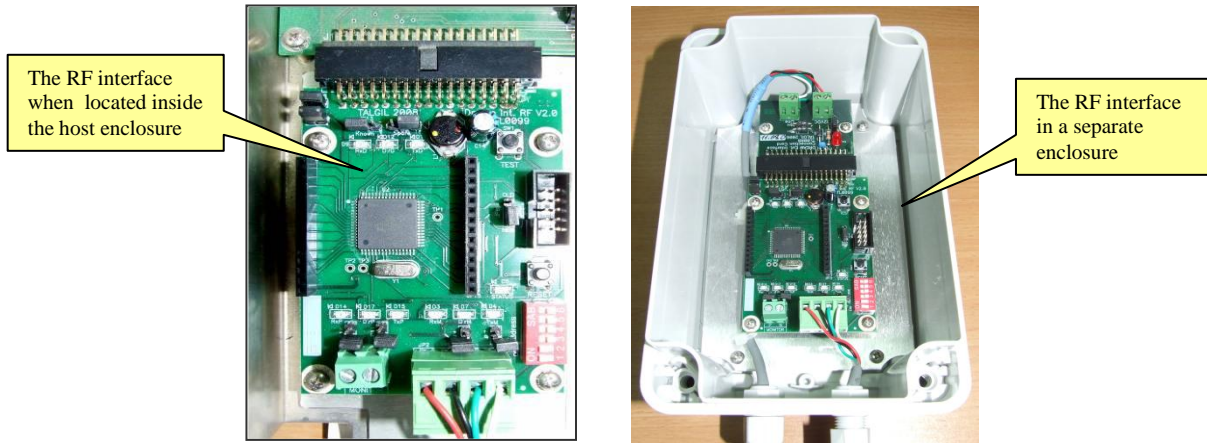

REMARK: The Oasis RF system does not use an interface.

3. The **RF RTU** – The RF RTU is the edge unit in the field, that communicates by radio with the Master, receiving and carrying out commands to open/close outputs, and reports back the status of inputs.

A single RF channel can handle as many as 60 RTUs.

There are 2 types of RTUs :

- a) **Modular** – the modular RTU may have up to 8 outputs (in steps of 2,4,6,8), 4 digital inputs and up to 4 analog inputs. The outputs activate 2 wired DC pulse latching solenoids. The ability of reading digital inputs can be added to any of the 60 RF RTU units however analog inputs are limited to the first 8 RTUs only.
- b) **Economical**– they come in two sizes – with 2 outputs and 2 digital inputs (2/2), or with 1 output and 1 input (1/1).

The modular RTU consists of 2 parts: one is called the RF SLAVE and the other is called the RF BASE. The 2 parts are connected by a shielded 4 wired cable the length of which should not exceed 10 meters.

3.1 The **RF SLAVE** is a receiver/transmitter unit including an antenna, installed on top of a high pole. The RF SLAVE is the part of the RTU that is in charge of the radio communication between the RF RTU and the controller.

3.2 The **RF RTU BASE (EXECUTER)** is in charge of the output and input activity of the RTU executing output commands and reading the inputs. It is located at the lower part of the pole at a convenient height for connecting the I/O devices to the unit.



In the Economical RF RTU the SLAVE and the BASE are combined into the same board:



For practical reasons the Economical RF RTU cannot be installed in a too high position, because then the wiring of the outputs and inputs will be too difficult. On the other hand if we install it in a low position we shall sacrifice the height of the antenna. In order to solve this problem we use an antenna extension kit:



Each RF RTU can act also as a REPEATER that can help reaching far RTUs or help reaching those that are hidden by obstacles. Such a unit can function both as an RTU and as a REPEATER at the same time.

! **NOTE :** The upper part of the pole holding the RF MASTER and RF SLAVE units must be made of nonmetallic material, otherwise the radio signal may suffer some power attenuation. **The construction of the poles must include facilities that will enable easy lowering.**

! **NOTE:** Despite the resemblance between the MASTER and SLAVE units, they are not interchangeable.

The RF RTU can be powered either by dry batteries or by rechargeable battery charged by solar energy. When powered by dry batteries it will use 6v DC, supplied by 4 x 1.5v “D” type standard alkaline batteries. When powered by solar energy, the RF RTU will contain a 12v 1.0Ah rechargeable battery. Regular RTU will use a 2 Watt solar panel, and those who serve as repeaters will use a 5 Watt solar panel.

Assuming ideal conditions, in an area with no obstacles and no interferences, the distance between the MASTER and a directly communicated RTU can reach about 2.5 -3km. By utilizing a REPEATER, the distance can be doubled.

2. SETTING UP AN RF RTU SYSTEM

The process of setting up an RF RTU system starts at the host controller (DREAM, UNILINER, MINILINER, OASIS) where some necessary definitions have to be made through which the controller is informed about the details of the RF system to be controlled (see below).

An appropriate location should be found for locating the pole of the RF MASTER. It should be not too far from the host controller and it should be as high as possible in order to assure a clear line of sight to most of the RTUs in the field. Remember that the upper part of the pole should be nonmetallic.

The RF INTERFACE that coordinates between the MASTER and the host controller can be located inside the host’s enclosure or externally. When external it will come in a separate box and both sides of the interface the one that is connected to the host and the one that is connected to the Master will use a shielded 4 wired cable for connection. The red and the black wires supply the power (12v DC) and the green and white wires support the communication; in both cases the polarity is important, follow the directions below. The shield will be connected together with the black wire.

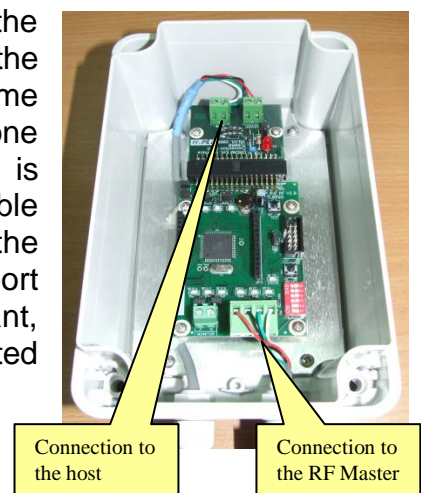

Out in the field, each RTU BASE (EXECUTER) and its RF SLAVE counterpart will also be installed on a pole with the SLAVE unit on top of the pole and the RTU BASE about 1 meter above ground. Here again the upper part of the pole, where the RF slave is located, should be of nonmetallic material and here too the connection between the SLAVE and the RTU BASE uses a shielded 4 wired cable.



2.1 SETTINGS TO BE DONE AT THE HOST CONTROLLER

We shall use the DREAM controller for demonstration; however the same kind of definitions should be done when the host is a UNILINER, MINILINER or OASIS. The DREAM can handle several RF channels. Each channel will have its own interface, its own RF MASTER and its own RTUs. The channels must use different frequencies and they will be recognized by the address given to the RF INTERFACE of the particular channel.

The screens below show the hardware definition to be made at the DREAM in order to make the DREAM recognize the various interfaces included in the system.

HARDWARE DEFINITION	
Interface card type	Quant.
DC I/O interface	2
AC I/O interface	0
4 wired RTU int.	0
2 wired RTU int.	1
RF RTU interface	1
Line int SyncBUS	0
Analogs I/O interface	0

HARDWARE DEFINITION DETAILS				
Adr	1	2	3	4
IntDC	16:8	-	-	-
IntDC	2 16:8	16:8	-	-
Int2W	3			
IntRF	4 10.0			

Declaring the number of RF interfaces

The address of the RF interface

The scanning rate 10 sec

Next to the address of the RF INTERFACE there is a definition of the scanning rate by which the DREAM is exchanging information with the RTUs.

The following options exist: scanning every 10sec; 5sec; 2.5sec or 1.25 sec. For energy saving purposes low scanning rate should be preferred, though too low scanning rate may cause losing pulses of water meters and fertilizer meters having high flow rates. Therefore the scanning interval should not be longer than the shortest expected OPEN or CLOSED contact condition. When this condition cannot be met, pulse dividers should be used (see explanation below). **On the other hand, the scanning rate cannot be decided without taking into consideration the number of RTUs to be scanned. A scanning rate of 1.25 seconds will limit the number of RTUs to 7, (the system will recognize RTUs with addresses from 1 to 7). With scanning rate of 2.5 sec, it will recognize RTUs 1 to 15, with scanning rate of 5 sec, it will recognize RTUs 1 to 31 and with scanning rate of 10 sec, it will recognize all the range of 60 RTUs.**

The next step is the definition of the connections table in which the physical connection point of each I/O device is defined. During this procedure the host is informed about the addresses of the RTUs existing on the particular channel, and which I/O devices are connected to each.

CONNECTION OF-		Inputs		
Device		Adr	RTU	Inp
Watermeter	Src.B	4	17	1
Watermeter	Ln.1	4	1	1
Watermeter	Ln.2	4	3	1
Watermeter	Ln.3	4	5	1
Watermeter	Ln.4	4	7	1
Watermeter	Ln.5	4	9	1
Watermeter	Ln.6	4	13	1
	Auto	X		--▶

2.2 SETTING UP THE INTERFACE AND THE RF MASTER

The RF INTERFACE has been designed to support the GIII and GIV versions, but it can be compatible with older versions as well. When used with the previous generation MASTER (up to version 7.8) jumper JP6 should be set to “OLD” position and when used with a MASTER of version 7.9 or higher, JP6 should be in “NEW” position (see picture below). Talking about compatibility it must be pointed out that Master of version 7.9 or higher cannot work properly with interface of the old generation, therefore if there is a need to replace a Master of version 7.8 or lower with a Master of version 7.9 or higher it forces the replacement of the old RF interface to the new one as well.

To indicate that the system contains analog inputs that are supposed to be read through the RF RTU system, JP13 must be set in left position, leaving the right pin free as in the picture below.

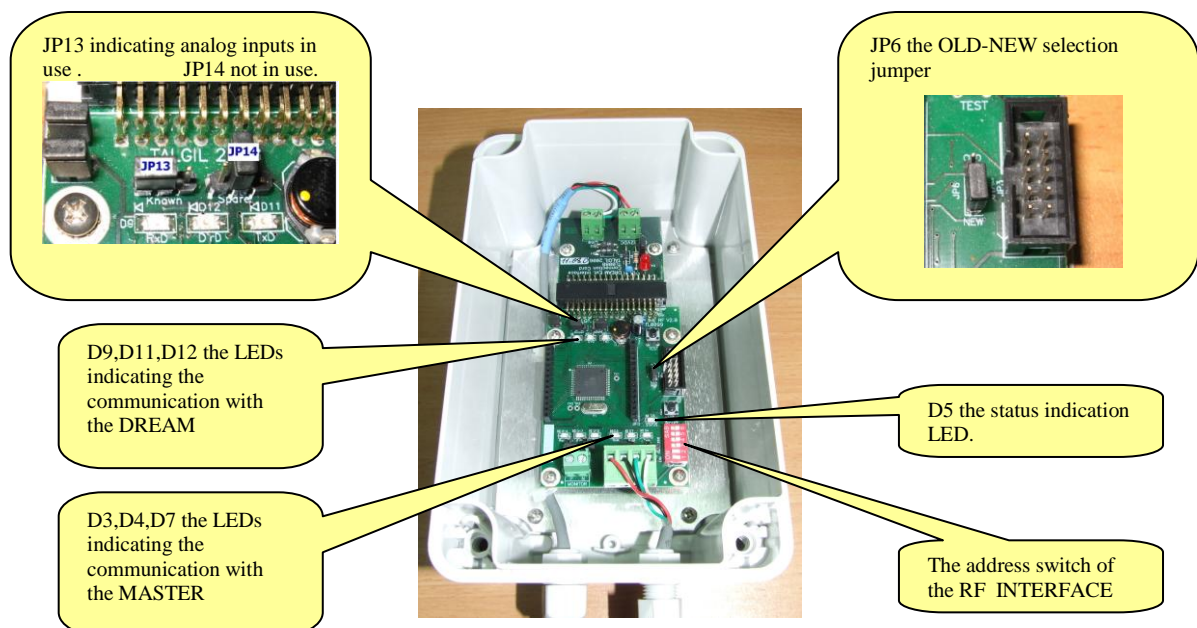

Setting the channel address is done by use of the Address Dip Switches. The address must be set according to the address defined at the DREAM (or other host) controller. Make sure that there is no other interface with the same address. Notice that the addressing uses binary coding. See “Appendix A” about the binary to decimal conversion.

The interface board contains a status indication led D5 that supplies the following information:

- **Lighting constantly** – indicates having no configuration loaded from the host which is a fault of course.
- **Blinking fast** – indicates having no communication with the MASTER.
- **Blinking slowly** – indicates a mistake in the definition of the analog inputs, they are supposed to be allocated to a dummy analog interface whose address must be one above the address of the RF INTERFACE itself.
- **Light off** – indicates normal operation.

The LEDs D9,D11,D12 show the communication with the DREAM. They are supposed to blink each second. The LEDs D3,D4,D7 show the communication with the MASTER, when working with an old generation MASTER they will blink fast, and when working with a new generation MASTER they will blink according to the selected scanning rate.

At the RF MASTER the only setting required is for selecting the RF FREQUENCY to be used. There are 16 frequencies to choose from. The frequency selection must take into consideration frequencies already being used by neighboring systems. The selection of the RF frequency is done by the Dipswitch S1 (frequency).

Channel number	DIP SWITCH S1			
	pos1	pos2	pos3	pos4
1	OFF	OFF	OFF	OFF
2	ON	OFF	OFF	OFF
3	OFF	ON	OFF	OFF
4	ON	ON	OFF	OFF
5	OFF	OFF	ON	OFF
6	ON	OFF	ON	OFF
7	OFF	ON	ON	OFF
8	ON	ON	ON	OFF
9	OFF	OFF	OFF	ON
10	ON	OFF	OFF	ON
11	OFF	ON	OFF	ON
12	ON	ON	OFF	ON
13	OFF	OFF	ON	ON
14	ON	OFF	ON	ON
15	OFF	ON	ON	ON
16	ON	ON	ON	ON



When there are DREAM RF systems in close vicinity, or when a DREAM system utilizes several channels, one channel may disturb the operation of the others. To

eliminate disturbance between the systems the frequency selection should be according to the following tables:

Two channels system		Three channels system		
First channel	Options for the second channel	First channel	Second channel	Options for the third channel
1	07, 08, 09, 10, 12, 13, 14, 15, 16	1	7	13, 14, 15, 16
2	08, 09, 10, 11, 12, 13, 14, 15, 16	1	8	14, 15, 16
3	09, 10, 11, 12, 14, 15, 16	1	9	15, 16
4	10, 11, 12, 13, 14, 15, 16	1	10	16
5	11, 12, 13, 14, 15, 16	2	8	14, 15, 16
6	12, 13, 15, 16	2	9	15, 16
7	01, 13, 14, 15, 16	2	10	16
8	01, 02, 14, 15, 16	3	9	15, 16
9	01, 02, 03, 15, 16	3	10	16
10	01, 02, 03, 04, 16	4	10	16
11	02, 03, 04, 05			
12	01, 02, 03, 04, 05, 06			
13	01, 02, 04, 05, 06, 07			
14	01, 02, 03, 04, 05, 07, 08			
15	01, 02, 03, 04, 05, 06, 07, 08, 09			
16	01, 02, 03, 04, 05, 06, 07, 08, 09, 10			

On the RF MASTER board, there are 5 LEDs. The three LEDs - D3; D4 and D5 indicate the communication with the RF INTERFACE and when the communication functions properly, they blink fast. The red LED ● D2 blinks each time the RF MASTER is calling any of the RTUs, so during each scanning cycle it will blink several times according to the number of RTUs defined. Each time the RF MASTER picks up a proper response of an RTU, it makes a short beep sound by its buzzer 📢, so during each scanning cycle when there are several RTUs responding to the MASTER each in its turn, there will be a series of beep sounds 📢📢📢📢📢.....📢📢.

2.3 SETTING UP THE RF SLAVE

The only setting required at the RF SLAVE is the setting of Dipswitch S1 (frequency). The selected frequency should be identical to the selected frequency at the RF MASTER board (see paragraph above).

REMARK: Starting from GIII the frequency setting can be done at the RF Base instead of at the RF SLAVE (see below), this feature enables changing the frequency without lowering the pole on which the slave is installed.

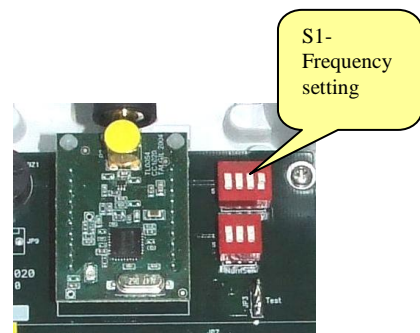

2.4 SETTING UP THE RF RTU BASE OR THE ECONOMICAL RTU

The following pictures describe the RF RTU base (executer) board, and the ECONOMICAL RTU board.

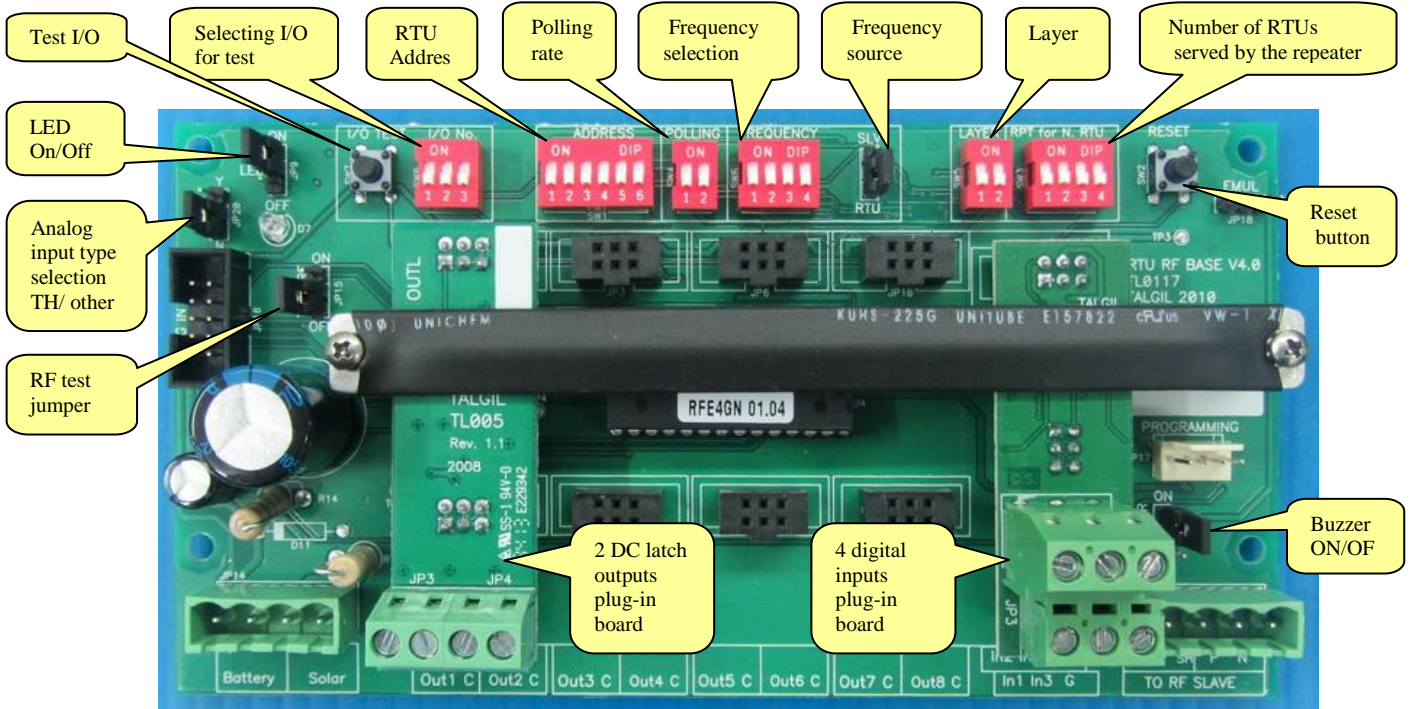

The ECONOMICAL RF RTU includes all the functions of the MODULAR RF RTU except for analog inputs and the ability of expanding the outputs.

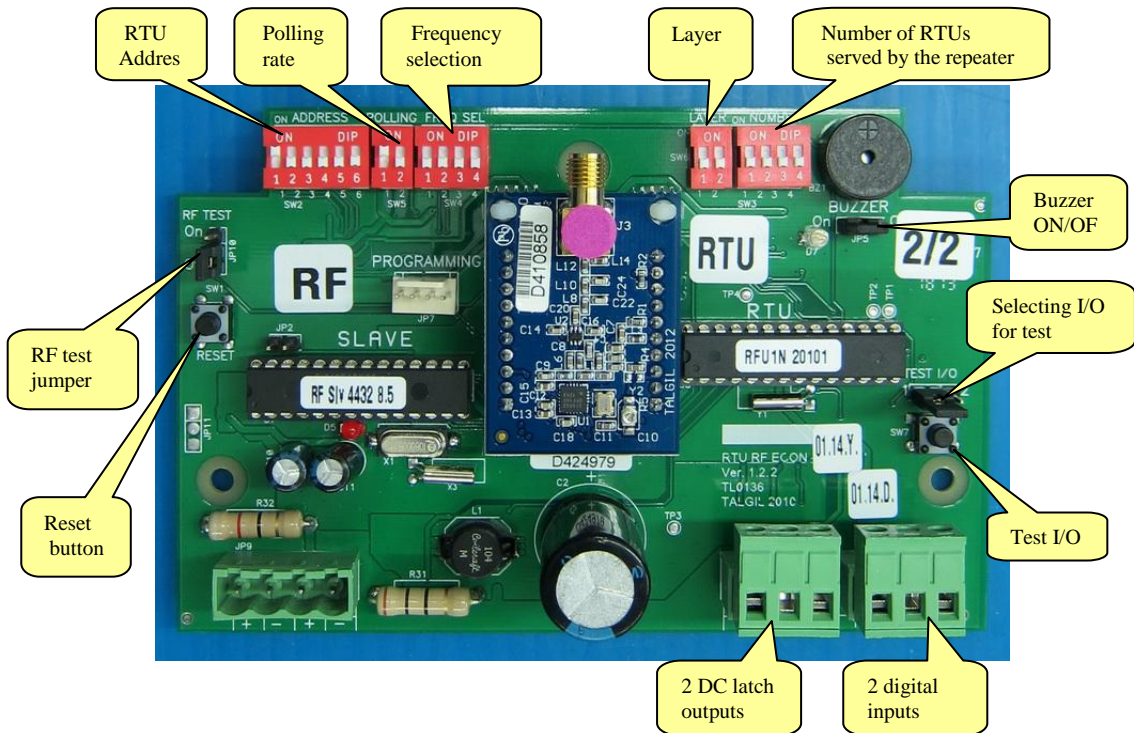



Before being able to use the RTU there are some necessary settings to be done:

- **Setting the address of the RTU**
- **Setting the polling rate by which the MASTER is communicating with the RTUs**
- **Setting the layer of the RTU. The layer defines whether the RTU communicates directly with the MASTER or through a REPEATER. (See below the explanation about repeaters).**
- **For RTUs serving as repeaters, it is necessary to define the number of RTUs that are serviced by the repeater.**
- **Setting the communication frequency. In the old generation the frequency setting could only be done at the SLAVE board. Starting from GIII the frequency can be set at the BASE board as well, therefore the source of frequency need to be selected.**

2.4.1 Setting the RTU address

SW1- Defines the address of the specific RTU. The addressing uses binary notation (see Appendix A about the binary to decimal conversion). Each RTU must have its own unique address in the range 1 to 60. However the selection of the address must obey some rules depending on the polling rate and the use of REPEATERS as explained below.

2.4.2 Defining the polling rate

SW4- Defines the polling rate (known also as scanning rate) by which the MASTER is communicating with the RTUs. The setting of the polling rate should be identical in all RTUs and equal to what has been defined at the host controller. The selection of the scanning rate is not totally free, it must take into consideration the total number of RTUs that need to be scanned, or more accurately the highest address to be scanned. The following table shows what will be the highest address recognizable at any scanning rate selected, and the combination needed at SW4 for selecting each polling rate.

SW4 –	pos 1	pos 2	The polling rate (sec)	Highest RTU address
	0	0	10	60
	1	0	5	31
	0	1	2.5	15
	1	1	1.25	7

2.4.3 Setting the layer

SW5- Defines the layer to which the specific RTU belongs. RTU that communicates directly with the Master without going through a REPEATER is said to belong to layer “0” and those that communicate through a REPEATER belong to layer “1”. The directly communicating RTUs will have SW5 set to “00”, and RTUs that communicate via a REPEATER will have SW5 set to “10”.

2.4.4 Setting up a repeater

When some RTUs have difficulty to communicate directly with the MASTER because of a disturbing obstacle or too long distance, there is a necessity to use a REPEATER. Both the RTU serving as a REPEATER and those using its services, need to be informed about the arrangement. The following settings are required:

SW3- When SW3 is set to a nonzero value, the RTU becomes a REPEATER and the value of SW3 represents the number of RTUs using the services of the REPEATER. The number is expressed in binary notation (see Appendix A about the binary to decimal conversion). For all the RTUs that are not repeaters, SW3 must be set to "0". In the example below, RTU No 2 is a repeater for 3 units therefore switch SW3 of RTU No 2 should be set to 3.

Now the question is how does the REPEATER know exactly which RTUs it is serving? The answer lies in the addresses of those RTUs. The first RTU must have the address of the REPEATER +1, the second must have the address of the REPEATER +3, the third will have the address of the REPEATER + 5 etc...

As mentioned above, all RTUs that are directly communicating with the MASTER, without using a REPEATER, belong to layer "0". The RTUs that are functioning as REPEATERS belong also to layer "0". Only the RTUs that are communicated via REPEATERS are considered to belong to layer "1". Each of the units of layer "0" occupy a single address, but those who belong to layer "1" occupy 2 addresses, therefore the immediately following address of such RTUs must be skipped. Therefore RTUs that are communicating via repeaters differ from regular RTUs by two things: first they belong to layer "1" and second they occupy two addresses instead of one.



Notice that the first RTU communicating through a repeater will get the address immediately following the address of the REPEATER. The other RTUs communicating via the REPEATER will have a gap of 1 from the former RTU address.



There is no predefined limit to the number of REPEATERS that can be used in an RF system. However the number of RTUs using the same repeater is limited to 15.

EXAMPLE – The drawing shows a system utilizing a repeater. There are 3 RTUs using RTU No. 2 as a REPEATER, these units belong to layer "1" while the REPEATER and the other RTUs belong to layer "0". The units that communicate through the REPEATER have the addresses "3", "5" and "7" and the addresses "4", "6", "8" are skipped, they cannot be used.

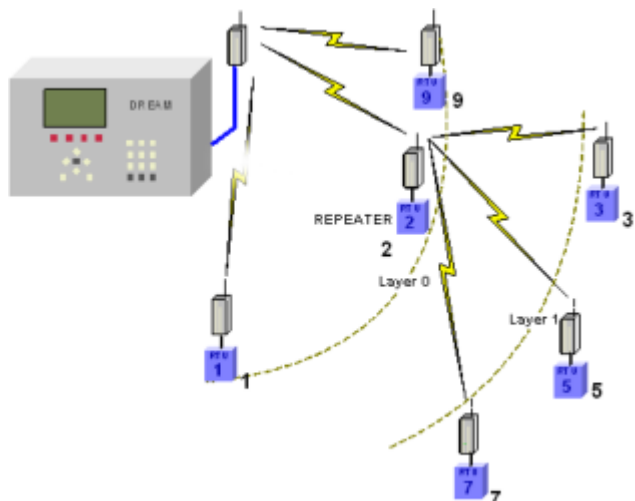



2.4.5 Functions of the jumpers

JP5- When in the upper position, the buzzer is enabled.

JP15- When set to the upper position, a request for RF testing mode is sent to the DREAM controller. (see paragraph 3.3 below about the RF test mode).

3. THE VARIOUS MODES OF OPERATION

3.1 START-UP MODE

Right after energizing the RTU or after pushing its reset button there is an initialization process that starts with a sequence of 3 short and one long beeps 📢📢📢📢 after which the solenoids are closed one by one. Every 15 seconds 2 short beeps 📢📢 will be sounded and every 30 seconds the slave will try to acquire communication with the MASTER. During the process of acquiring communication the red LED ● of the SLAVE turns on indicating that the receiver is open and listening. This takes about 10 seconds. If the communication is established, the RTU goes into NORMAL MODE, otherwise it will keep trying to pick up the communication signal every 30 seconds.

3.2 NORMAL MODE

During normal mode of operation, the RTUs are scanned by the host via the MASTER one by one in a cyclic manner and in a constant rate. In each cycle, every RTU is communicated within its allocated timeslot, which is dictated by its address. During that timeslot, an information exchange takes place, the required state of the outputs is sent from the host controller to the RTU, and the current state of inputs is transmitted back to the host controller. The rate of scanning must be identically set both at the host controller and at each RTU. When the MASTER initiates a scanning cycle there will be a blink of the MASTER's LED ● and for each response received correctly from any RTU, there will be a short beep 📢 sounded by the MASTER's buzzer.

At the other end the RF SLAVE which is dormant between the scanning cycles, wakes up at the right timeslot and prepares itself for receiving the transmission of the MASTER. This state is indicated by a blink of the SLAVE's LED ●. Each time a successful information exchange takes place there will be a short beep sound 📢 made by the buzzers of both the RTU BASE and the RF SLAVE. If the RTU picks up the signal from the MASTER but the call was not correctly addressed, it will sound a double beep 📢📢. For those who have difficulty hearing the buzzer, the green LED ● blinks each time the buzzer sounds.

3.3 RF TEST MODE

The purpose of this test is to check the communication quality between a specific RTU and the MASTER. Prior to initiating the TEST mode, it must be enabled at the host controller. When enabled, the request for RF TEST is initiated from the RTU. By setting JP15 to "RF test" (upper position) a test request signal is sent to the Master. When the request is received by the MASTER, it is immediately granted and the RF test starts. During RF TEST mode the regular scanning of all the RTUs is stopped and the MASTER starts communicating solely with the RTU under test

second by second. The red LED of the SLAVE is constantly ON ●. The rate of communication becomes once per second. Each second the Master transmits to the RTU the signal strength picked up by the Master from the RTU and the RTU responds by transmitting to the Master the signal strength picked up by the RTU from the Master. Listening (by the RF Ear) to the exchange of information between the Master and the RTU under test, one can tell exactly how they hear each other.

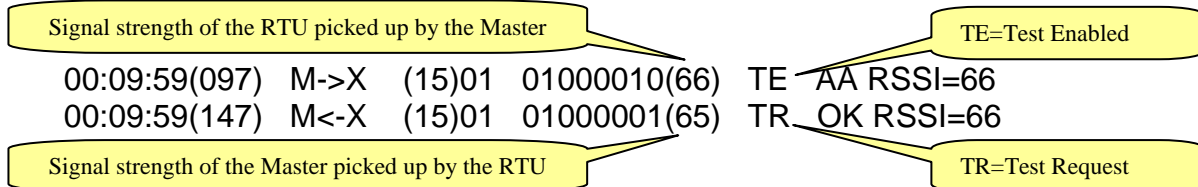

The MASTER will remain in TEST mode until receiving an END OF TEST signal from the RTU (as a result of removing jumper 15) or until the RF TEST is disabled by the user at the host controller.

3.4 WHEN LOSING COMMUNICATION

The reaction of the RTU in case of losing communication with the host can be initially programmed. The following options exist: 1) to leave the outputs as they are 2) to shut down the open outputs after a predefined delay (Autoclose). Every 30 seconds the unit will try seeking the communication signal of the MASTER. During this process every 15-second a double beep 📢 📢 will sound, and every 30 seconds the red ● LED of the SLAVE will turn on for 10 seconds indicating that the receiver is open trying to pick up the communication signal. This will continue for 1 hour and then for energy saving purposes the RTU instead of seeking communication every 30 seconds will start seeking communication **only once every hour**. When the communication signal is regained, the RTU returns to its normal state.



Notice that if the MASTER was OFF for more than an hour, then when it is turned ON again, the RTUs may not respond immediately to the calls of the MASTER, because they are in energy saving mode. It may take an hour before they start responding. They can be forced to exit energy saving mode by pushing the RESET button of the RTU.

3.5 TESTING INPUTS AND OUTPUTS

During test mode the inputs and outputs are tested one by one. The input and output to be tested is selected by dipswitch block SW6 as follows:

SW6	Input/ Output under test
000	1
100	2
010	3
110	4
001	5
101	6
011	7
111	8



INPUT TEST – The test begins by pushing the TEST button SW7. Each change of state of the selected input will be indicated by a short beep of the buzzer, single beep for closing the contact and double beep for opening.

OUTPUT TEST – While being in INPUT TEST, pushing SW7 again, will terminate the INPUT TEST and will start the OUTPUT TEST. An "open" command will be sent to the selected output followed by a single beep 🔔. Another push of SW7 generates a "close" command indicated by a double beep 🔔 🔔. Each push of SW7 will switch the solenoid between "open" and "close" positions.

To exit test mode change the position of SW6 or wait 1 minute and it will exit automatically.

3.6 LOW BATTERY INDICATION

When the battery of an RTU gets too low, there will be a LOW BATTERY indication both at the RTU and at the host controller.

At the RTU, the low battery is indicated by a sound of 3 beeps 🔔 🔔 🔔 sounded every few seconds.

When is the battery considered low? The system decides on low battery situation by two criterions: one is the voltage of the battery and the second is the time it takes to recharge the capacitor after execution of an output command. For example, if the powering voltage is 6v, then low battery starts to be signaled when the battery drops to 4.8 volts or when the recharging time is longer than 5 seconds. At this stage the normal operation continues but the user is informed that the battery should be replaced. If the voltage drops further to 3.6v the beeping stops and all outputs will be shut down, since the unit is no longer able to continue communicating with the MASTER.

4. READING ANALOG INPUTS BY RF RTUS

Starting from GENERATION III the RF RTU system is capable of reading analog inputs. This ability is limited to the RTUs addressed 1 up to 8 only. Currently the only host that recognizes the analog values is the DREAM controller. We shall now describe the necessary settings and definitions for enabling analog inputs reading through the RF RTU system.

4.1 SETTING THE INTERFACE FOR ANALOG INPUTS

To enable reading analog inputs the interface must be set as follows:

JP6 – must be set with upper pin free (NEW)

JP13 – must be set with right pin free (ANALOG ENABLED)

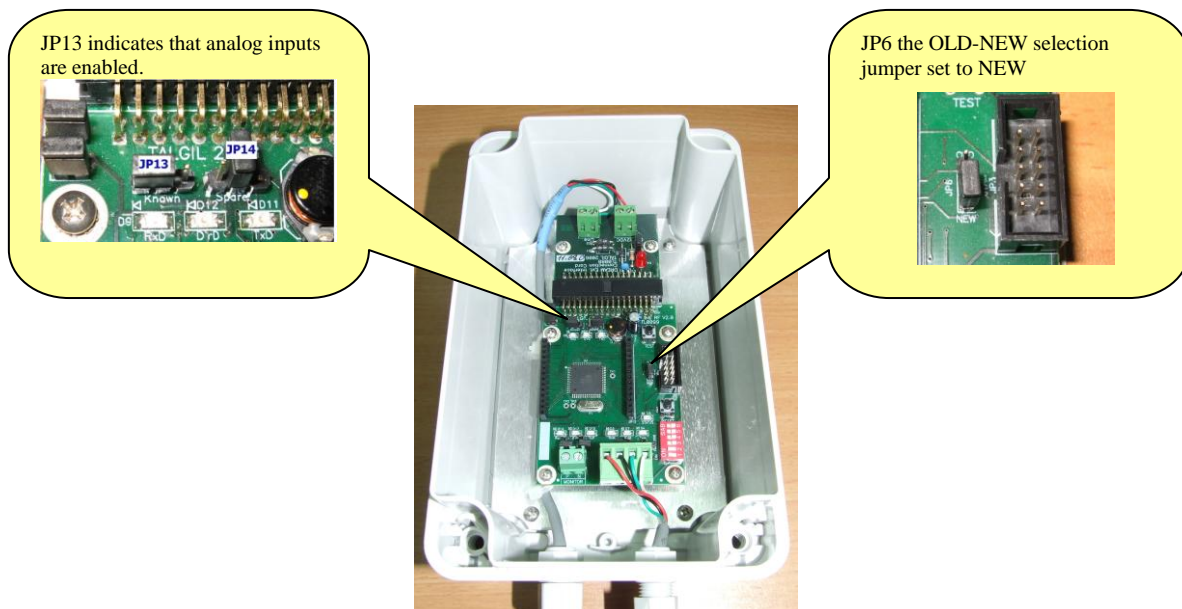

The RF MASTER needs no special setting but it must be version 7.9 or higher.

4.2 SETTING THE RTU FOR ANALOG INPUTS

To enable reading analog inputs the RTU must be equipped with a special EXPANSION BOARD OF ANALOG INPUTS that can handle up to 4 analog inputs. The analog inputs are additional to the 4 digital inputs that the RTU can read when equipped with the appropriate plug in board.

The number of analog inputs that will really be used and the way the analog inputs will be powered is defined by programming the RTU BASE board.

For that purpose a special communication interface and special software "RFProg" are used.

During programming, the interface will be connected in place of the SLAVE communication lines as demonstrated below. The PC software "RFProg" communicates with the RTU through the interface and enables setting the desired

parameters as explained below at the paragraph about “PROGRAMMING THE RTU”.

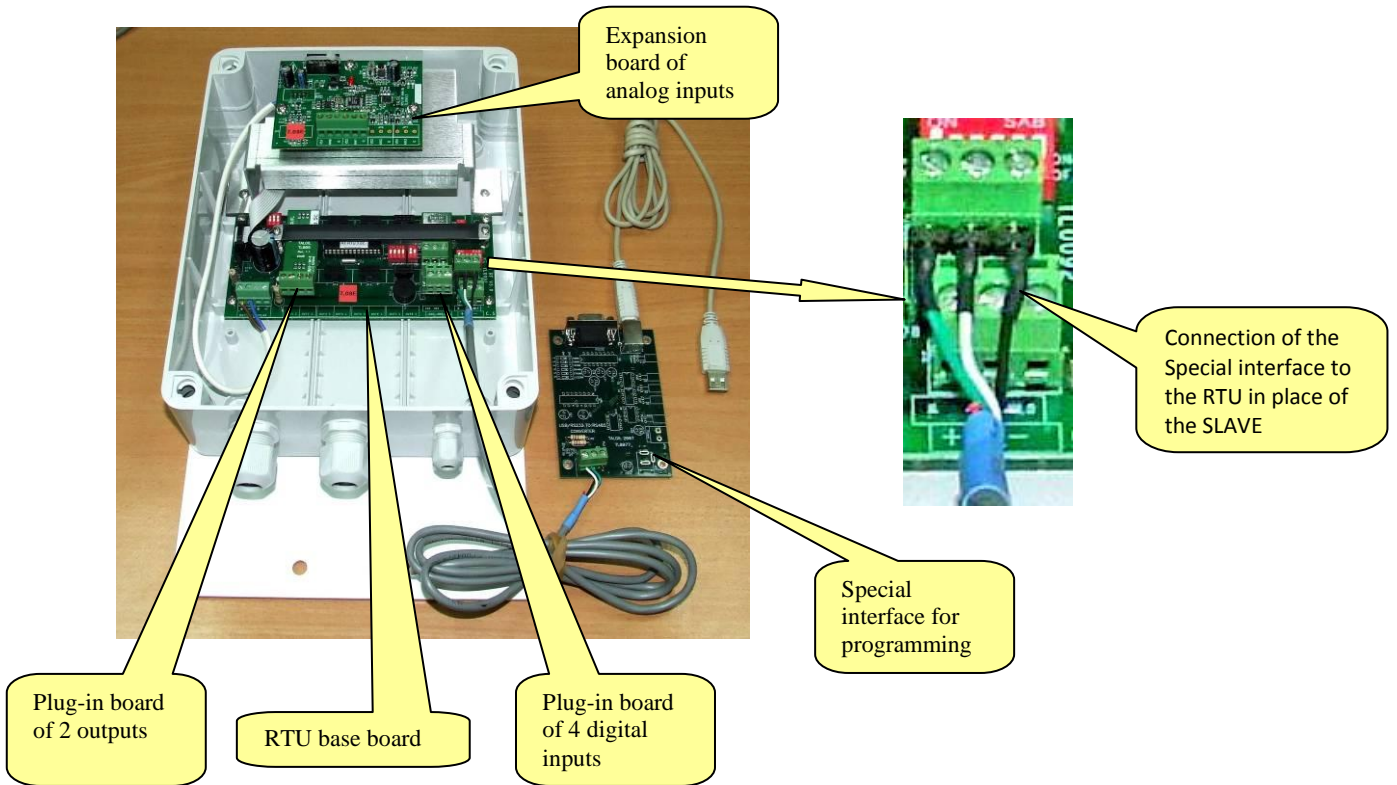

In case of sensor of 4-20 mA, a 221Ω resistor will be used as shown in the picture. Usually the board will be supplied with the resistors included. In case of 0-5v the resistors should be removed.

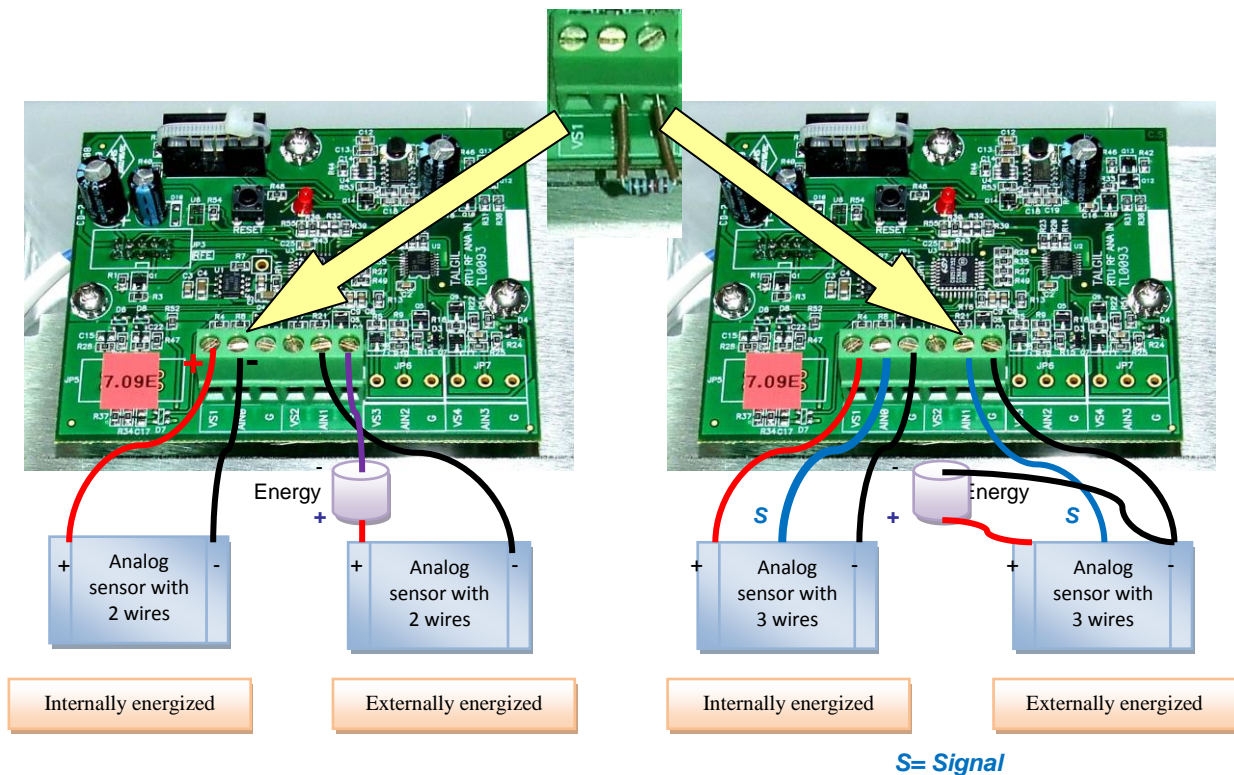

4.3 SETTING THE DREAM FOR READING RF ANALOG INPUTS

For being able to read analog inputs through the RF RTU system the DREAM host controller must have the following definitions made:

1. At the NETWORK DEFINITION stage the number of analog inputs must be declared.
2. At the HARDWARE DEFINITION stage a virtual ANALOG INTERFACE must be declared and given an address that is higher by 1 than the address of the RF INTERFACE through which the analog values will be transmitted.
3. At the CONNECTION DEFINITION stage the analog inputs must be defined as connected to a virtual analog RTU belonging to the channel of the virtual analog interface but with the same RTU number as the RF RTU to which the analog input is really connected.
4. The RF RTU to which the analog input is connected must have at least 1 output and 1 digital input allocated to. If such allocation does not really exist, a dummy output and a dummy digital input must be defined and allocated to the specified RTU.
5. At the UTILITIES/ANALOG-SENSORS definition the type of each analog sensor and its scale range should be defined.



The resolution of the analog inputs is 16 bits and they are transmitted in nibbles of 4 bits per cycle, therefore it takes 4 cycles of communication to transfer the value of a single analog input and if there are 4 analog inputs connected to the same RTU it may take at least 16 communication cycles to transfer 4 analog inputs. If a nibble was not successfully received by the MASTER it will be requested again on the next communication cycle.

5. USING RFPROG FOR PROGRAMMING THE RTU

By use of the RFProg (special software for programming the RF RTU) the following parameters of the RF RTU can be set:

- Parameters involved with the analog inputs
- Parameters involved with the solenoids activation pulse
- Parameters involved with the input pulses division
- Parameters involved with the Auto-close in case of losing communication

To prepare for programming the RTU base must be energized by 6-12 volts and must be put into “programming mode” by holding down the TEST button (SW7) and then pushing the RESET button (SW2). Being in programming mode is indicated by a single beep (and single blink ●) every 6 seconds. Make sure that the RTU address is set to a nonzero value. When programming a modular RF RTU the connector of the cable between the Slave and the Executer must be pulled out.

Initially the software must be informed about the communication port of the PC to which the special communication interface is connected. Notice that if the interface is connected to a USB port, the CONTROL-PANEL/ SYSTEM/ HADWARE/ DEVICE MANAGER should be checked to find out which comport was the USB serial output allocated to.

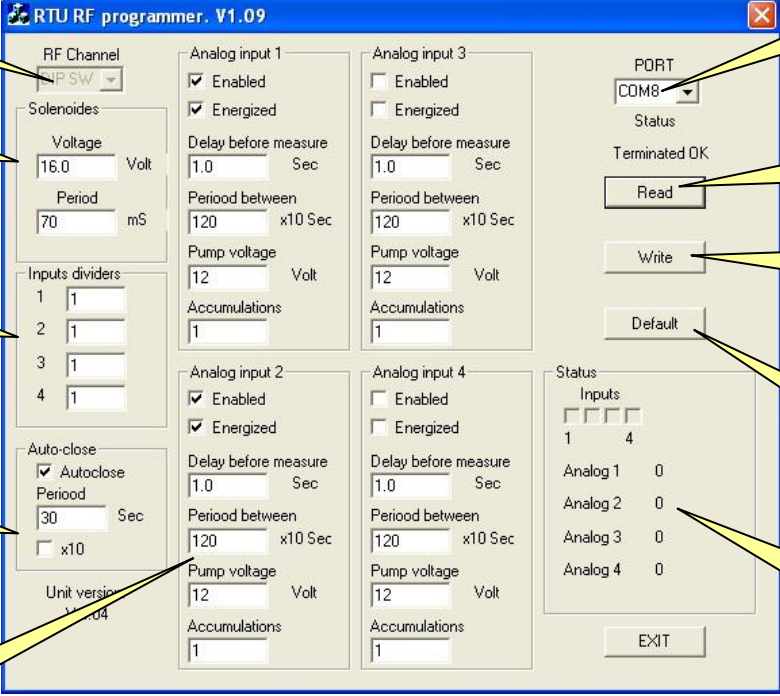

The screenshot shows the RTU RF programmer V1.09 interface. Callouts point to various features:

- Not in use:** Points to the RF Channel dropdown menu.
- Setting the solenoids pulse parameters:** Points to the Solenoids section with Voltage (16.0 Volt) and Period (70 mS) fields.
- Inputs pulses division factors:** Points to the Inputs dividers section with four input fields set to 1.
- Auto close cycle and permission checkbox:** Points to the Auto-close section with the Autoclose checkbox checked and Period (30 Sec) set.
- Setting analog inputs parameters:** Points to the Analog input 1 section.
- Selected com port:** Points to the PORT dropdown menu set to COM8.
- Read programmed parameters:** Points to the Read button.
- Write programmed parameters:** Points to the Write button.
- Setting default parameters:** Points to the Default button.
- Displaying statuses of digital and analog inputs:** Points to the Status section showing digital inputs (1, 4) and analog inputs (Analog 1-4) all set to 0.

5.1 ANALOG INPUTS PARAMETERS

When the checkbox of an analog input is enabled, it indicates that the input is recognized by the RTU. The input can be energized by external energy source or internally from the RF RTU itself. When internally energized the energy to the sensor is generated inside the EXPANSION BOARD OF ANALOG INPUTS and for energy saving purposes it is supplied to the sensor, each time, only a short while before reading. The cycle of reading, the voltage supplied and the delay between cycles of reading can be defined as shown below.

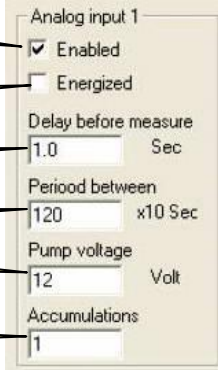

The close-up shows the Analog input 1 parameters with callouts:

- Enabled analog input checkbox:** Points to the checked 'Enabled' checkbox.
- When checked indicates internally energizing:** Points to the 'Energized' checkbox, which is unchecked.
- Delay between energizing and reading:** Points to the 'Delay before measure' field set to 1.0 Sec.
- Interval between cycles of reading in steps of 10 seconds:** Points to the 'Period between' field set to 120 x10 Sec.
- The voltage generated for reading:** Points to the 'Pump voltage' field set to 12 Volt.
- Number of samples used for obtaining the average value:** Points to the 'Accumulations' field set to 1.

5.2 THE SOLENOIDS ACTIVATION PULSE PARAMETERS

For optimal solenoid activation and for energy optimizing the G III –GIV RF RTU units enable defining the pulse amplitude and pulse width used for activating the solenoids.

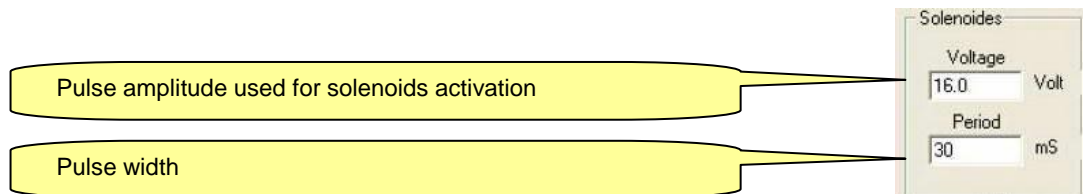

5.3 INPUTS PULSE DIVISION

Because the rate of pulses arriving to the digital inputs from water meters and fertilizer meters may sometimes be higher than the scanning rate between the MASTER and RTUs, it may be needed to count several pulses before transmitting to the host. This is known as pulse division. The division factor can be set individually per each input through the following table:

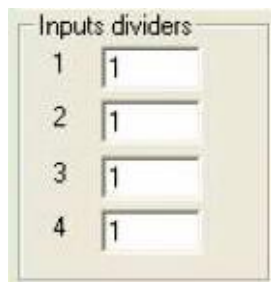

5.4 THE AUTO CLOSE PARAMETERS

It must be decided what will be the reaction in case of losing communication between the MASTER and an RTU. Sometimes we would like the outputs to be closed and sometime we prefer to leave them unchanged. The desired action can be decided in the following table:

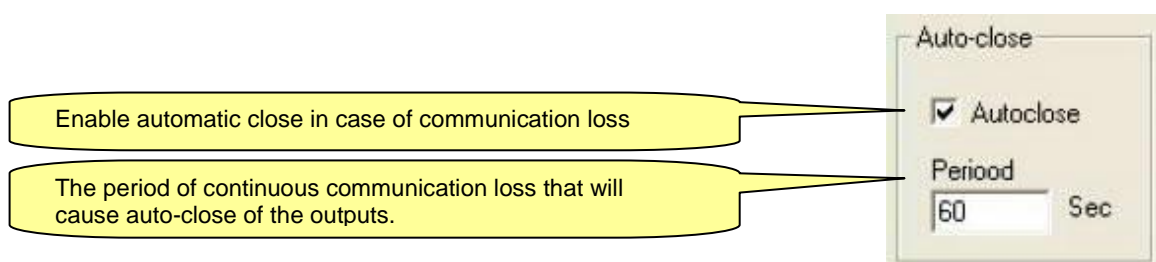

6. SOUNDS and LED LIGHTS

Longest beep -  (500 msec)

Long beep -  (100 msec)

Short beep -  (50 msec)

A tick -  (5 msec)

Long blink- 

Short blink- 

6.1 RTU+SLAVE during START UP

USER ACTION: connecting power or pushing the RESET button
 RTU ACTION: closing all outputs

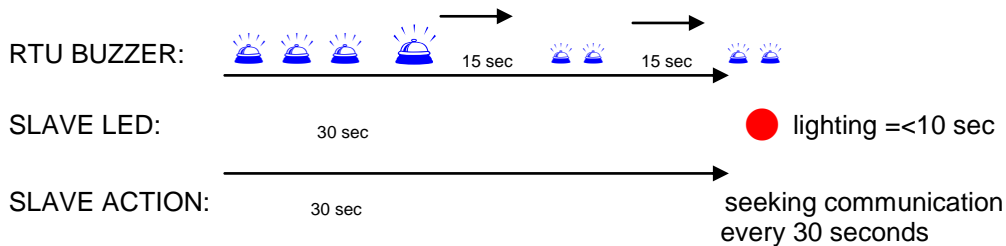

6.2 RTU BASE+SLAVE during normal communication

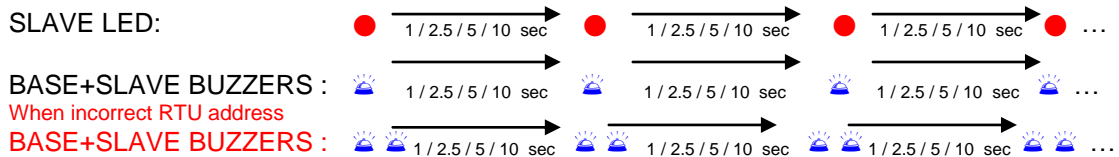

6.3 BASE+SLAVE while losing communication

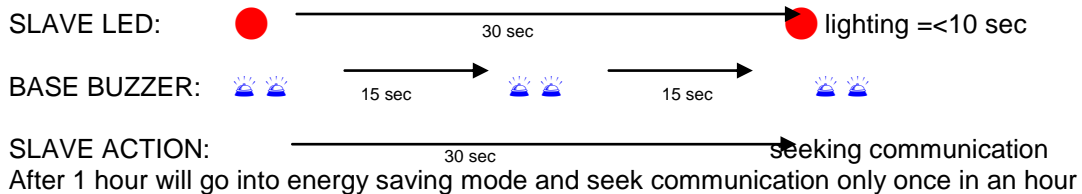

6.4 BASE+SLAVE during RF test - COMMUNICATION OK

USER ACTION: JP15 to lower position (upper pin free)

SLAVE LED:  lighting constantly

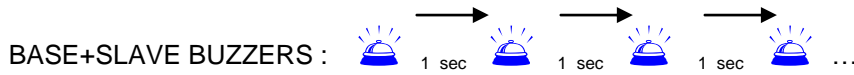

6.5 BASE+SLAVE during RF test – NOT RECEIVING

USER ACTION: JP15 to lower position (upper pin free)

SLAVE LED:  lighting constantly

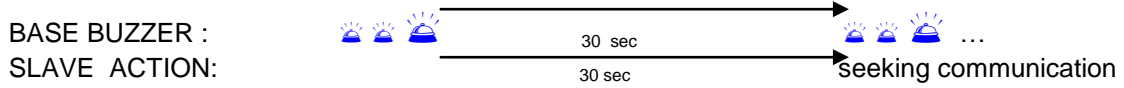

6.6 No communication between BASE and SLAVE

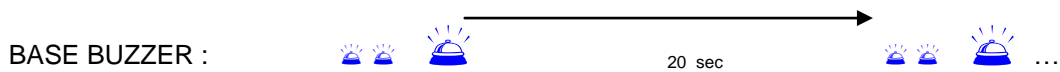

6.7 BASE during inputs test



USER ACTION: selecting the desired input by SW6 and pushing TEST button

BASE BUZZER : 

USER ACTION: closing the selected input contact

BASE BUZZER : 

USER ACTION: opening the selected input contact

BASE BUZZER :  

6.8 BASE during outputs test



USER ACTION: selecting the desired output by SW6 and pushing TEST button once for entering test mode and again for opening the output

BASE ACTION: opens the selected output

BASE BUZZER : 

USER ACTION: pushing TEST button again

BASE ACTION: closes the selected output

BASE BUZZER :  

USER ACTION: keeps pushing repeatedly the TEST button for opening and closing the output. For ending the test procedure the RESET button should be pushed or else there will be an automatic exit after 1 minute of no changes sensed.

6.9 BASE when battery becomes low

BASE BUZZER :

 that follows any usual beep indicates low battery.

RTU ACTION:

When the battery becomes very low closing all outputs one by one and sounding  without any other sounds.

6.10 INTERFACE+MASTER during normal operation - RF OK

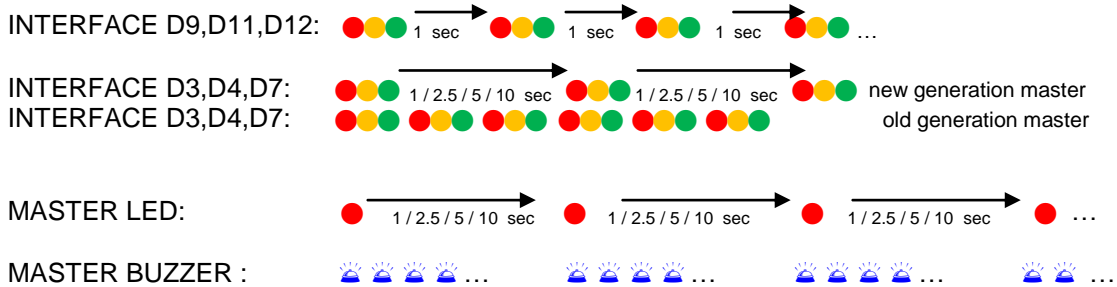

6.11 INTERFACE not communicating with the MASTER

INTERFACE D5:  ... blinking fast

6.12 INTERFACE not communicating with the DREAM

INTERFACE D9,D11,D12: no blinking

6.13 BASE ENTERING PROGRAMMING MODE

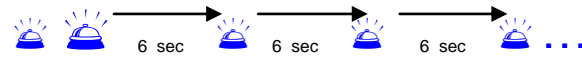

6.14 SLAVE ADDRESS ZERO





APPENDIX A - Decimal to binary conversion table

Decimal address	Binary value to be set by the Dip Switch						
	Positions:	1	2	3	4	5	6
1		1	0	0	0	0	0
2		0	1	0	0	0	0
3		1	1	0	0	0	0
4		0	0	1	0	0	0
5		1	0	1	0	0	0
6		0	1	1	0	0	0
7		1	1	1	0	0	0
8		0	0	0	1	0	0
9		1	0	0	1	0	0
10		0	1	0	1	0	0
11		1	1	0	1	0	0
12		0	0	1	1	0	0
13		1	0	1	1	0	0
14		0	1	1	1	0	0
15		1	1	1	1	0	0
16		0	0	0	0	1	0
17		1	0	0	0	1	0
18		0	1	0	0	1	0
19		1	1	0	0	1	0
20		0	0	1	0	1	0
21		1	0	1	0	1	0
22		0	1	1	0	1	0
23		1	1	1	0	1	0
24		0	0	0	1	1	0
25		1	0	0	1	1	0
26		0	1	0	1	1	0
27		1	1	0	1	1	0
28		0	0	1	1	1	0
29		1	0	1	1	1	0
30		0	1	1	1	1	0
31		1	1	1	1	1	0
32		0	0	0	0	0	1
33		1	0	0	0	0	1
34		0	1	0	0	0	1
35		1	1	0	0	0	1
36		0	0	1	0	0	1
37		1	0	1	0	0	1
38		0	1	1	0	0	1
39		1	1	1	0	0	1
40		0	0	0	1	0	1
41		1	0	0	1	0	1
42		0	1	0	1	0	1
43		1	1	0	1	0	1
44		0	0	1	1	0	1
45		1	0	1	1	0	1
46		0	1	1	1	0	1
47		1	1	1	1	0	1
48		0	0	0	0	1	1
49		1	0	0	0	1	1
50		0	1	0	0	1	1
51		1	1	0	0	1	1
52		0	0	1	0	1	1
53		1	0	1	0	1	1
54		0	1	1	0	1	1
55		1	1	1	0	1	1
56		0	0	0	1	1	1
57		1	0	0	1	1	1
58		0	1	0	1	1	1
59		1	1	0	1	1	1
60		0	0	1	1	1	1

APPENDIX B - WIRING

Wiring between DREAM – RF INTERFACE (internal) and RF MASTER

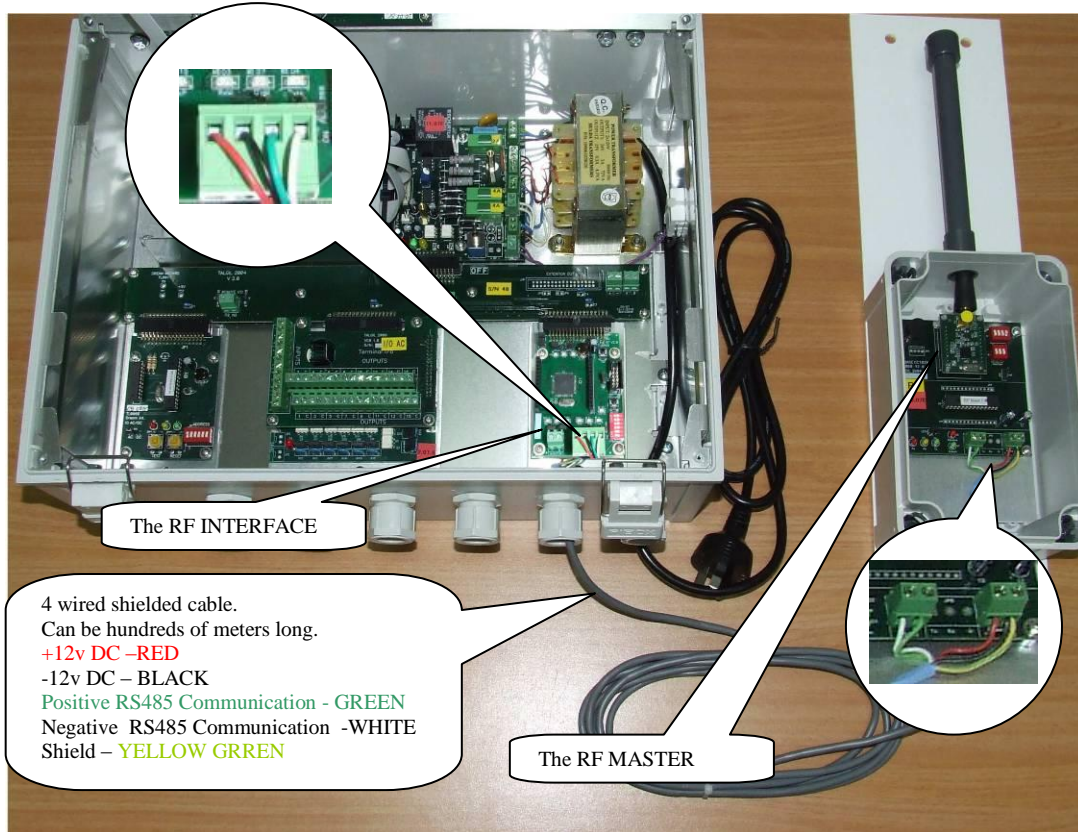

Wiring between DREAM – RF INTERFACE (internal) and RF MASTER

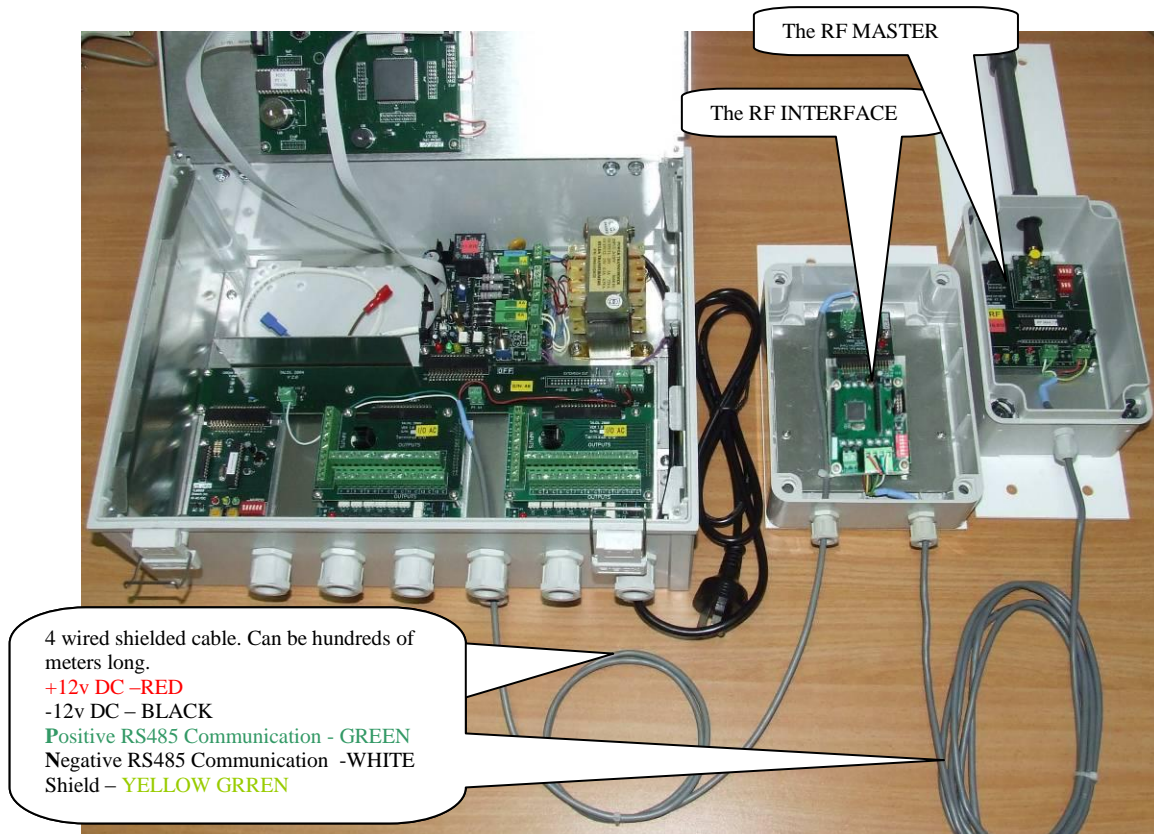

Wiring between RTU BASE and RF SLAVE

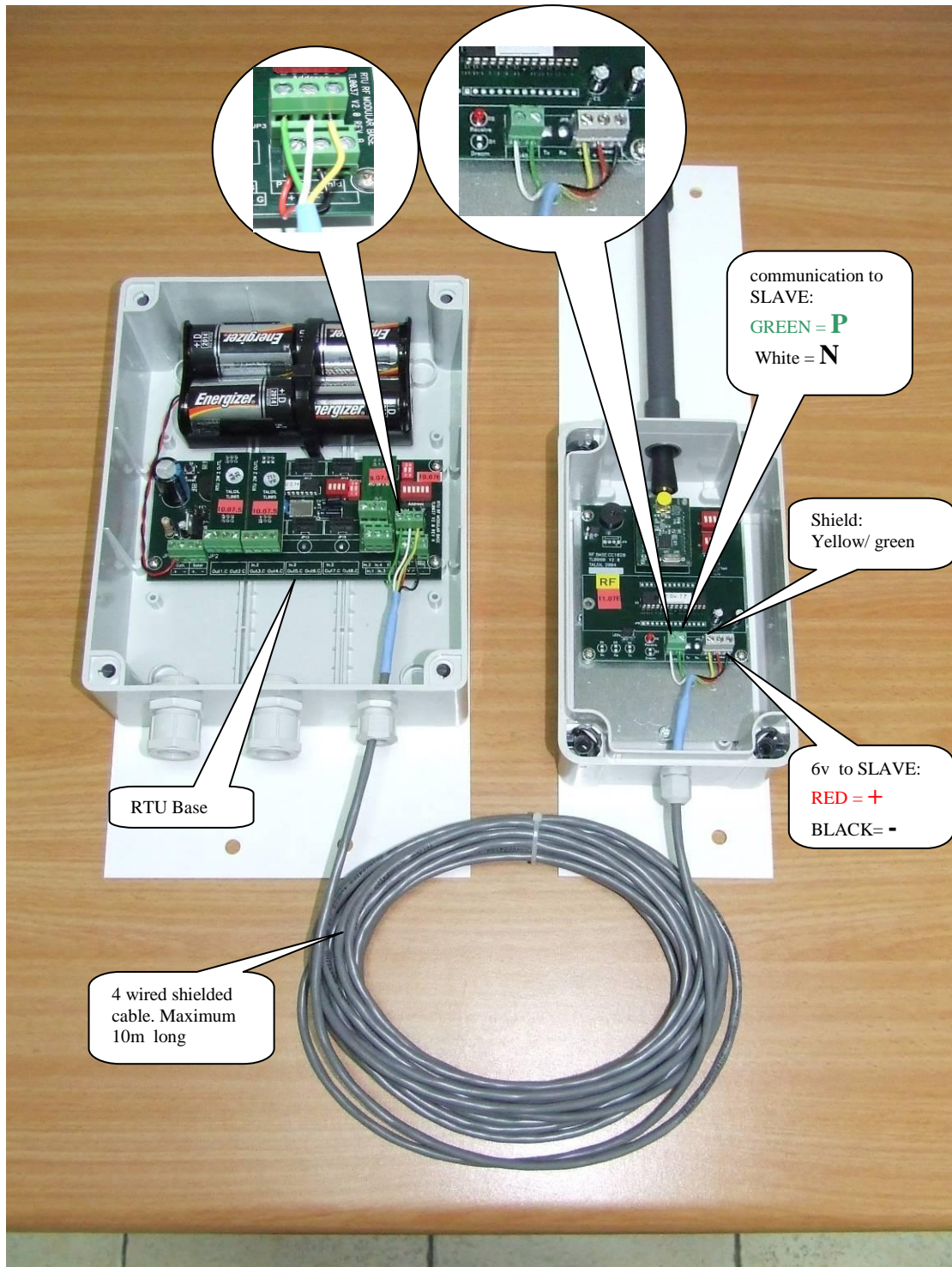

Wiring of Outputs and Inputs into the RTU BASE:

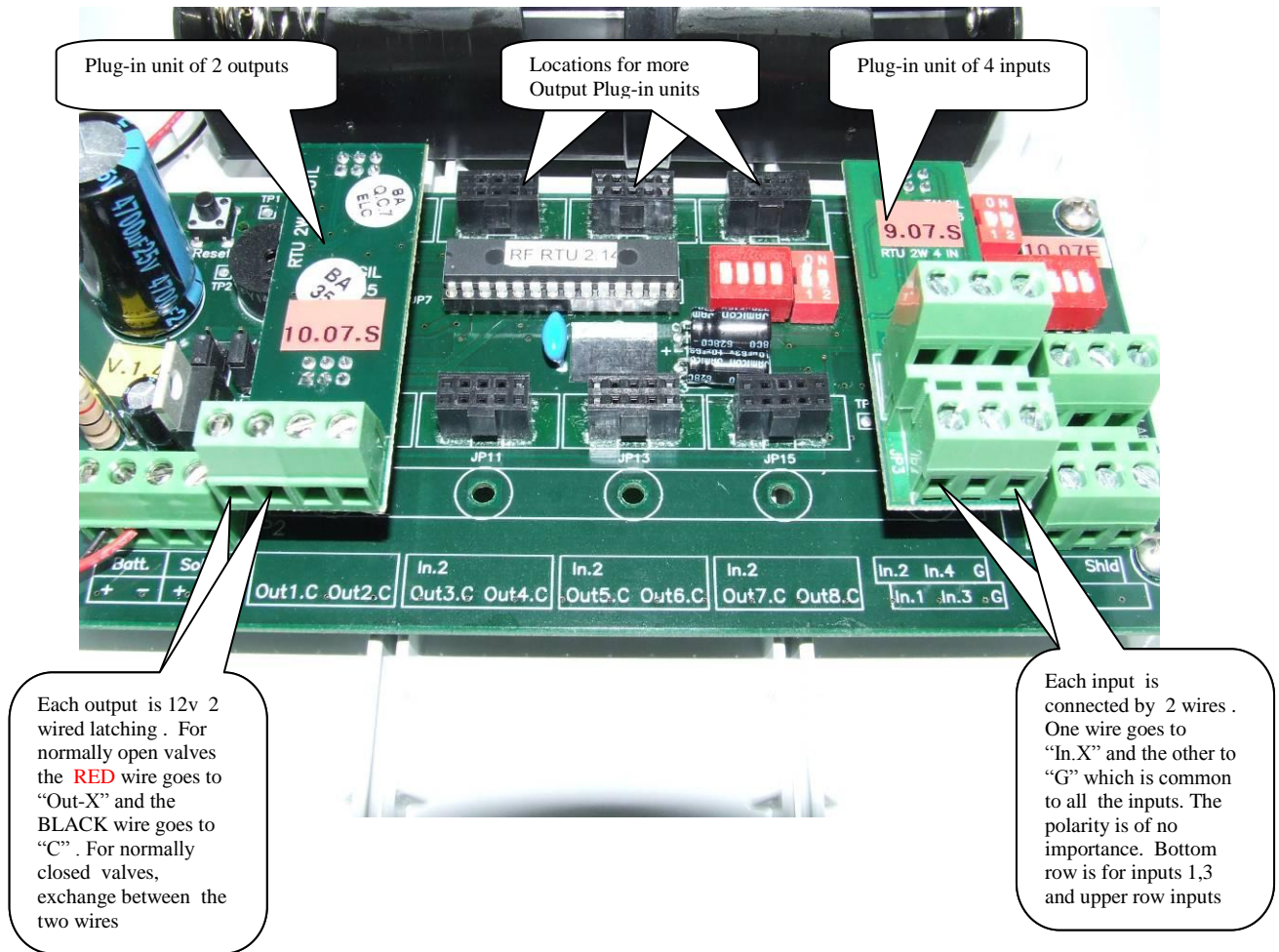

APPENDIX C – THE RF EAR

The RF EAR is a very efficient monitoring tool that supplies valuable information about the communication between the RF MASTER and the SLAVES of a particular system to which it is tuned.

The RF EAR contains an RF receiver/transmitter, which resembles the RF MASTER but functions in a totally different way – it does not transmit anything but it is continuously open for reception of any transmissions made by the members of the system. The RF EAR picks up only data transfer using the communication protocol utilized by Talgil RF systems and only if it is in the selected frequency. Therefore, the collected information shows the behavior of the particular system being tested, the information is displayed at a real time basis on the screen of a mobile PC and it is continuously recorded for later inspection.

By moving around with the RF EAR and recording the reception quality at the various RTU locations and at the center, one can identify the weak points of the system and decide about the solutions.

Usually the receiver/transmitter unit of the RF EAR will be installed on a long PVC pole that enables raising it high at the places being checked.

HOW TO USE THE RF EAR ?

1. Set the frequency channel of the RF EAR to the same frequency of the system being checked.

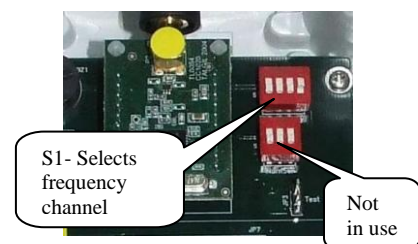

2. Turn on the power switch of the RF EAR. The unit will start sounding sequences of short beeps repeated in an interval of the scanning rate. Each short beep indicates a communication picked up by the unit.

- Turn on the laptop and activate the RF EAR software. The following window will appear:

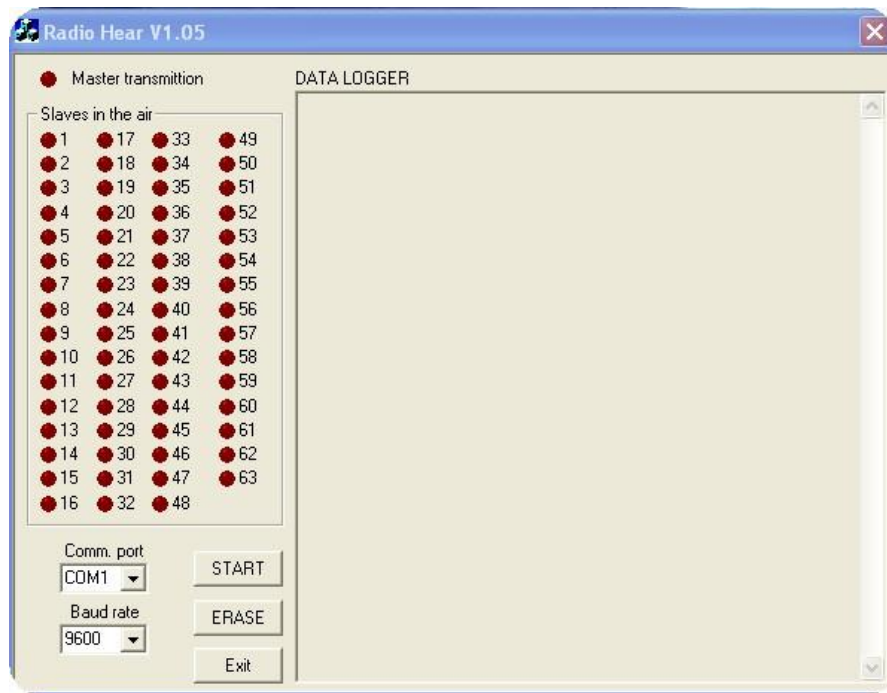

- Connect the communication cable of the RF EAR to a serial port of the laptop, and set the "Comm. Port" of the software accordingly. For those laptops having no serial port, a USB port with a converter from USB to RS232 can be used. For GIII the Baud rate setting should be 9600 while for GIV and GIV.V it should be set to 19200.
- Click on the START button, and the information received by the RF EAR will start to be displayed as shown in the following screen.

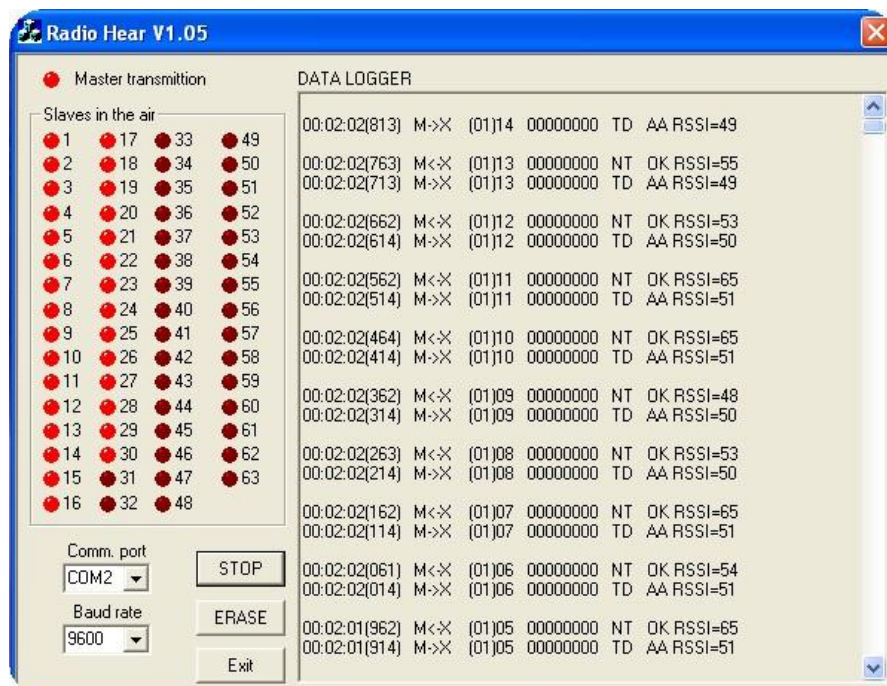

The display is refreshed each scanning cycle.

The drawings of the LEDS on the left side indicate the status of communication with each of the RF SLAVES (or with each RTU). An RTU, which responds properly, will be indicated by a LED lighting constantly. An RTU that did not respond the call of the MASTER will be indicated by a blinking LED. The RTUs that were not called by the MASTER either because they are undefined or because the call of the MASTER was not received remain dark.

On the right side of the window appear rows of characters that describe the information transmitted either by the MASTER or by one of the SLAVES. The rows are shifted downward with each new row received by the RF EAR.

The following row contains information about the MASTER's transmission :

00:01:05(852) M->X (04)02 00000000(00) TD AA RSSI=66

The time at which the communication took place.. The brackets contain milliseconds.

M - > X indicates a call from the MASTER to SLAVE - X

The number of the SLAVE -X is 2. The number in brackets is the selected frequency channel.

The status of the outputs-each bit represents 1 out of 8 outputs. "0" means closed, "1" means open.

The RSSI indicates the strength of the MASTER'S signal:
For GIII:
41-73 = Strong
34-40 = Medium
20-33 = Low

The response of the slave has the following format:

00:01:05(901) M<-X (04)02 00000010(02) NT OK RSSI=66

M <- X indicates the response from SLAVE - X to the MASTER.

The status of the inputs-each bit represents 1 out of 4 outputs. "0" means open contact, "1" means closed contact.

The RSSI indicates the strength of the SLAVE'S signal:
For GIII:
41-73 = Strong
34-40 = Medium
20-33 = Low

Notice that in the 8 bits string containing the status of the outputs or the inputs the rightmost digit represents the lower Output/Input bit.

When an RTU is defined to communicate through a REPEATER, there will be 4 rows describing the process: 1) the call of the MASTER; 2) the transfer of the call to the SLAVE by the REPEATER; 3) the response of the SLAVE and 4) the transfer of the response to the MASTER by the REPEATER.

In the following example the MASTER is calling RTU 3 which communicates through a REPEATER:

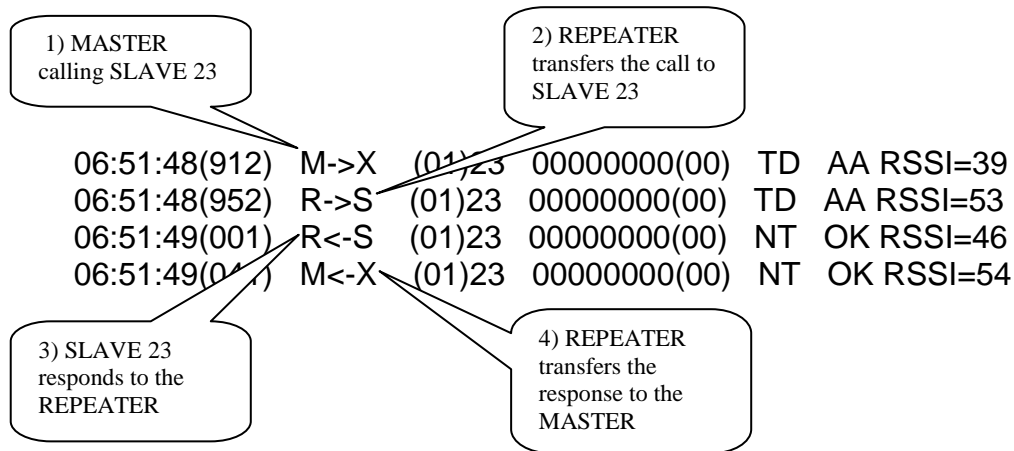

6. The recorded results are stored in text files called rfd0000.txt, rfd0001.txt, rfd0002.txt etc... Each time we exit and restart the RF EAR software a new file with a higher index is generated, thus eliminating the erasure of the previously recorded information. The following rows are taken from a file of recorded information. Notice that the first row shows the earliest record and there is exactly 100 milisec between the calls of the Master to the next RTU.

```

New loop: 12:47:18
00:00:34(629) M->X (01)01 00000001(01) TD AA RSSI=66
00:00:34(678) M<-X (01)01 00000000(00) NT OK RSSI=66

00:00:34(729) M->X (01)02 00000010(02) TD AA RSSI=66
00:00:34(778) M<-X (01)02 00000000(00) NT OK RSSI=66

00:00:34(829) M->X (01)03 00000100(04) TD AA RSSI=66
00:00:34(880) M<-X (01)03 00000000(00) NT OK RSSI=66

00:00:34(929) M->X (01)04 00000000(00) TD AA RSSI=66
00:00:34(981) M<-X (01)04 00000000(00) NT OK RSSI=66
*****
  
```

Each asterisk (*) that follows a communication cycle indicates an additional cycle which ended with identical results to the previous one.

APPENDIX D –

DIFFERENCES BETWEEN NEW/OLD RTU RF BASE BOARDS

** - actual from Slave version 7.12 or higher

